

## Application

volumetric / gravimetric feeding of solids.

Pellets     Micro-Pellets     Grind     Powder     Fibers

## SCHOLZ SOLO

### Single-Screw Feeder.

- cost-effective solution for high dosing capacities
- proven many times for regrind, recycling material, etc.
- extensive, modular hopper system
- made in Germany

### Dosing-capacity of the SCHOLZ Series

kg/h (bei 0,8kg/l)	0,1	1	5	10	50	100	500	1.000	5.000	10.000	25.000
LOGO											
MONO+											
<b>SOLO</b>											
GOLO											

Screws:             $\varnothing$  40mm to  $\varnothing$  100mm in spiral / full-blade /  
with core / double-helix / notched / special

Tube-Outlet:     $\varnothing$  50mm to  $\varnothing$  134mm horizontal / vertical

Hopper:            23 Liter Volume

Add. Hopper:    68 to 210 Liter, expandable

Lid:                 for manual / automatical refilling /  
Flap-Lid / Plexiglass / for Conveyors

Options:           Agitator, ATEX, Run Control

Material:          Stainless Steel 1.4301

Weight:            appr. 30kgs (without add. hoppers)

Dimensions:     350x350x350mm (DxWxH)

Gear-motor:      A  $i=5,1$      $\Delta$ 230V A W 50Hz / Y400V A W 50Hz  
B  $i=17,8$     $\Delta$ 230V A W 50Hz / Y400V A W 50Hz  
C  $i=60$       $\Delta$ 230V A W 50Hz / Y400V A W 50Hz

Agitator (Option):             $\Delta$ 230V A W 50Hz / Y400V A W 50Hz

## LOSS-IN-WEIGHT FEEDER RATIO

In combination with a SCHOLZ BASIC platform scale, you have a gravimetric feeding-scale.

Scale :             **BASIC400**

Capacity :        75 / 150 / 300kg

Platform :        400 x 400mm

Scale :            490 x 400 x 150mm (DxWxH)

Material :        Alu / Stainless Steel

Execution:        plug & play

Own weight:     11kgs

The SCHOLZ-CON-TRUST control system enables single- and multi-component operation.

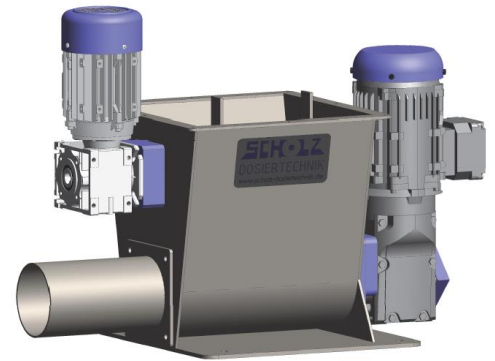

SOLO with horizontal Tube-Outlet with Agitator as optional equipment



SOLO with 130-Liter-Hopper and vertikl Tube-Outlet placed on platform-scale BASIC400

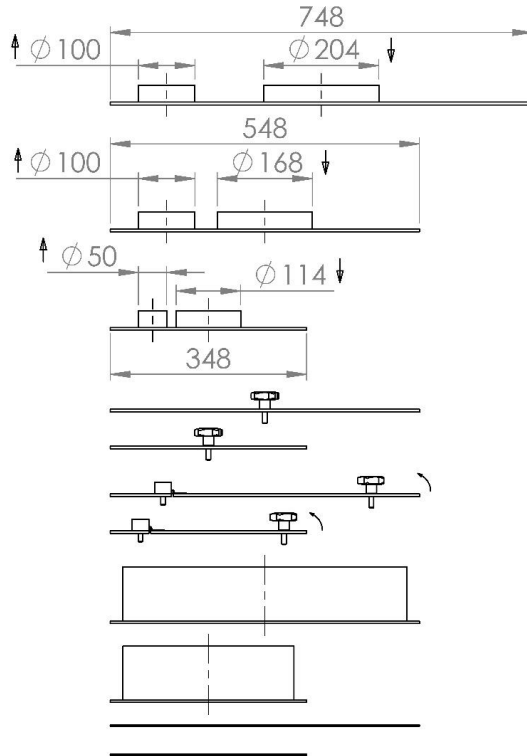

**AUTO LID**

AL-77	7,5 kg
AL-55	4,0 kg
AL-33	1,8 kg

**MANUAL LID**

ML-55	4,5 kg
ML-33	2,0 kg

**FLAP LID**

FL-55	4,7 kg
FL-33	2,2 kg

**BASIC HOPPER**

BH-025-551	5,0 kg
BH-009-331	2,5 kg

**SAFETY GRID**

SG-55	1,6 kg
SG-33	0,7 kg

**BASIC HOPPER**

BH-210-378	30,0 kg
BH-130-358	25,0 kg
BH-098-356	19,0 kg
BH-068-354	14,0 kg

**STACK HOPPER**

SH-054-336	14,0 kg
------------	---------

**FEEDER**

SOLO	30,0 kg
Option 1 SOLO-RC RUN CONTROL	0,5 kg
Option 2 SOLO-HA HORIZONTAL AGITATOR	8,0 kg

**SCALE**

BASIC400	16,0 kg
Option 3 BASIC400-OC OUTLET COMPENSATION	1,5 kg

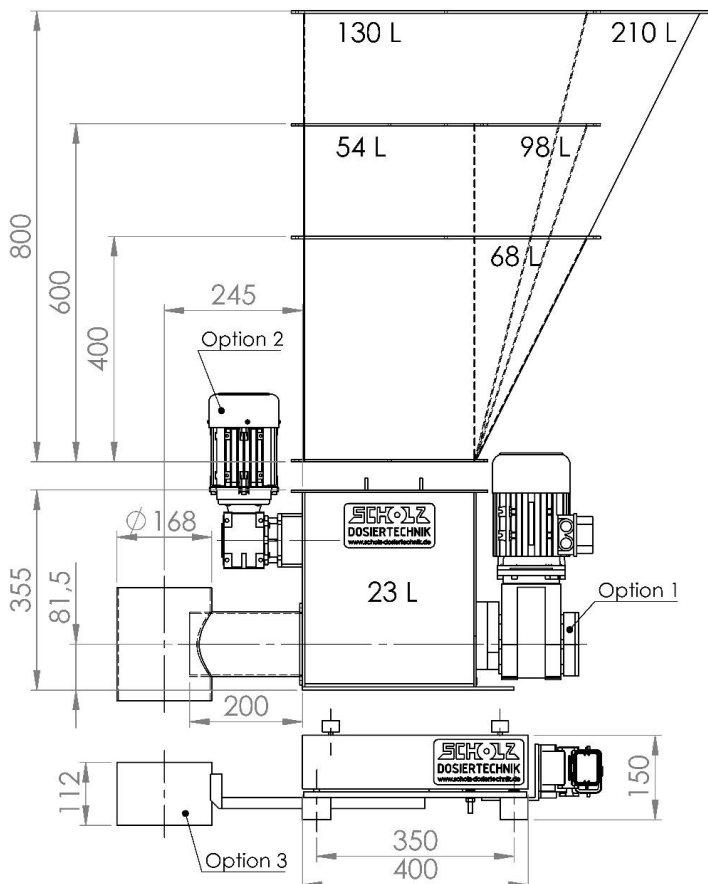

Differential-Dosierwage RATIO  
Loss-in-Weight-Feeder RATIO